

ArAS News

NEWSLETTER

ARMENIAN ASTRONOMICAL SOCIETY (A r A S)



No. 94 (June 30, 2016)

Editor: Sona FARMANYAN

ArAS Newsletter online at: <http://www.aras.am/ArasNews/arasnews.html>

CONTENTS

	1	BAO Observational Possibilities	3-10
	2	Kazakhstan and Tajikistan Joined IAU South West Asian ROAD	10-11
	3	Astrobiology Matters in Armenia	12-13
	4	"Cultural Astronomy in Armenian Highland" Young Scientists Conference	14
	5	ANSEF 2017 call	15-16
	6	ArAS Prize 2016 Call	17-18
	7	Release of Astrophysics Volume 59, Issue 2, June 2016	19
	8	Release of EAAS Astrocourier June Issue	20
	9	Release of IAU Astronomy Outreach Newsletter 2016 #12 June #3	21
	10	Lunar Phases of July	22
	11	July Calendar of Astronomical Events	23

BAO OBSERVATIONAL POSSIBILITIES

Currently the main instruments of Byurakan Astrophysical Observatory (BAO) are 2.6m reflector and 1m Schmidt telescope, which after recent modernization are operated again. Below the main observing possibilities and available instrumentation for these two instruments will be described.

2.6m telescope

This telescope was designed and constructed in LOMO (Sankt-Petersburg, Russia) and is in operation since 1976. During the economic crisis in Armenia it was stopped for five years (1991-1996). In 1996, new light receiving equipment has been installed with the help of French colleagues from Marseilles Observatory. This equipment included auto-guiding system, focal reducer and 1k×1k front-illuminated CCD detector.

The development of the light-receiving equipment at 2.6m telescope was continued in subsequent years, and presently we have two main instruments and the new CCD detector in operation.

Detectors. Starting from 1996 we had Thomson 1K CCD detector, working in half-obscured mode, specially designed for the scanning Fabry-Perot observations. Starting from 2000, at prime focus of the telescope the 2K front-illuminated Loral CCD was installed, providing 14'×14' field of view. Presently we have the new blue-sensitive back-illuminated Tektronix 1K CCD, which provides with SCORPIO camera the 11'×11' field of view. The new light-receiver, based on EEV 2K detector, is under construction and will become available for observations in 2016.

SCORPIO (Spectral Camera with Optical Reducer for Photometrical and Interferometrical Observations). Currently the majority of large and mid-size telescopes in the world are equipped with multi-mode faint object cameras. The main part of such systems is a focal reducer, which increases the equivalent focal ratio and the field of view of the system. The idea of using a focal reducer on a telescope was suggested and implemented by George Courtés at the 50-60ies of the last century (see, e.g., Courtés, 1960, 1964). Advantages, provided by focal reducer, are very important for the studies of the faint extended astronomical objects. Moreover, with focal reducer it becomes possible to install the dispersing elements (grisms, Fabry-Perot interferometer (FPI) etc.) in the parallel beam between the collimator and the camera, which turns the focal reducer into an universal spectrograph. It is worth

to mention that the first such device in Byurakan was the ByuFOSC camera on the 2.6-m telescope (Movsessian et al. 2000), which was in exploitation during 1997-1999.

SCORPIO camera allows the following observational modes of both extended and star-like objects to be performed at the prime focus of the 2.6-m telescope:

- Direct images with broad-, medium- and narrow-band filters.
- Panoramic spectroscopy with the FPI.
- Long-slit spectroscopy.
- Slitless spectroscopy.

Optical layout of the instrument is presented in the Fig. 1.

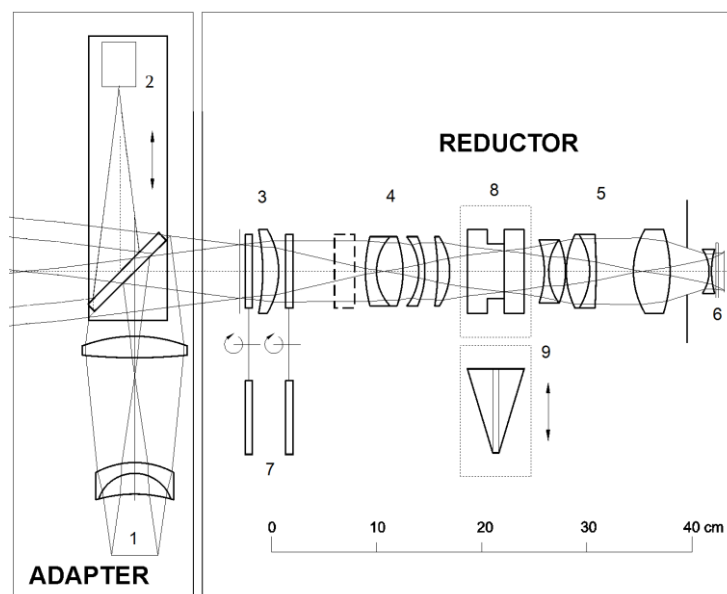

Fig. 1. Optical layout of SCORPIO. (1) – calibration optics, (2) – offset guiding system, (3) – field lens, (4) – collimator, (5) – camera, (6) – CCD, (7) – filter wheels, (8) – FPI, (9) – grism.

Starting from 2000 the same type of instrument is also in operation at the 6m telescope of SAO (Afanas'ev & Moiseev 2006). The mechanical and optical parts of SCORPIO system for both instruments were produced at the SAO model workshop. Basic parameters of the instrument equipped with TK1024 detector are given in Table 1.

Table 1. Basic parameters of SCORPIO.

Total focal ratio	F/2.6
Field of view	11'×11'
Image scale	0.67 arcsec/pix
Spectral range	3600-10000Å
Maximal quantum efficiency	
Direct imaging	70%
Spectroscopy	40%

SCORPIO is equipped with several filter sets that can be used for the photometric observations. Broad-band glass filters allow the Johnson-Cousins photometric UBVRCIc system to be implemented in direct imaging mode (see Bessell 1990). In addition the set of narrow-band filters, centered at the various emission lines (H α , [SII] etc.) also are available.

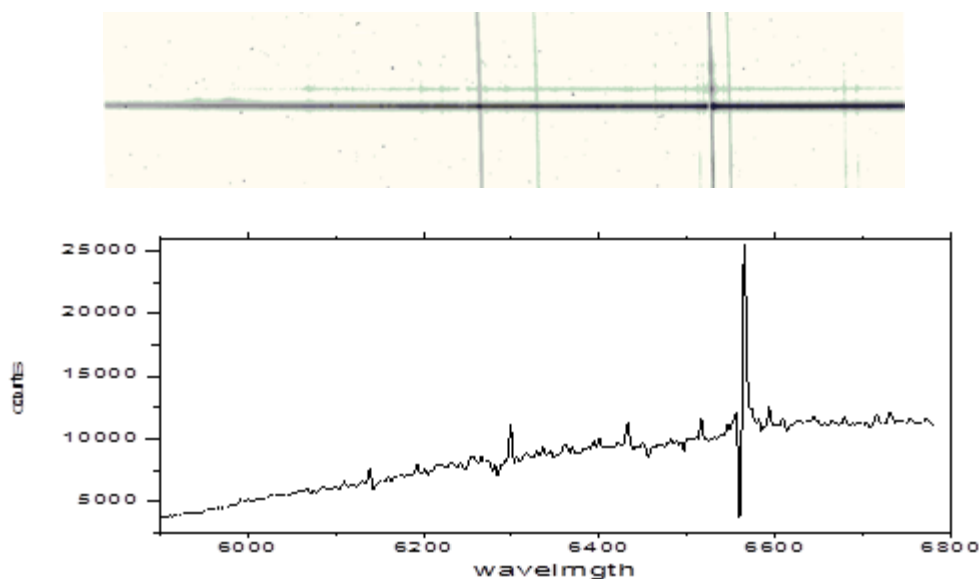

Fig. 2. Long-slit spectral image of LkHa 225 young stellar object (top) and its slice after the subtraction of night-sky spectrum are presented.

The pre-imaging possibility proves to be very useful in the slit spectroscopy of both extended objects (since the slit position becomes to be known exactly) and star-like objects if the latter are too faint to be visible on the TV-view. SCORPIO is equipped with set of gratings ensuring observations with different spectral resolution (from 1.5 to 20°Å with the slit width 1") in different regions of an optical spectrum.

On the Fig.2 the example of slit spectrum is presented.

Adapter. The platform adapter is used for the guiding, based on the off-axis stars, and for the illuminating the spectrograph by calibration lamps. Both the focal reducer and other equipment as well can be mounted on it. The flat diagonal mirror and guiding CCD are mounted on the movable table. This system allows inserting the on-axis field into guiding CCD for the precise pointing and afterwards shifting it to off-axis position for auto guiding. This mode is used when exposing objects. In addition, the light from the calibration lamps can be thrown into the spectrograph in the central position.

VAGR. This instrument realizes an elegant solution proposed by G. Courtés (1982) to achieve spectroscopic analysis of extended objects with a full 2D spatial coverage. The first realization was an integral field spectrograph TIGER on CFHT, presently the OASIS project. This concept, based on a micro-lenses array, allows to retrieving three dimensions (2D spatial and 1D spectral) information on 2D detector without the loss of sensitivity associated with time-scanning schemes. Another solution was realized on 6 m telescope in MPFS_spectrograph where fibers were used to rearrange micro-pupils into pseudo slit, which allows wide spectral range. In general, these two designs are quite complementary.

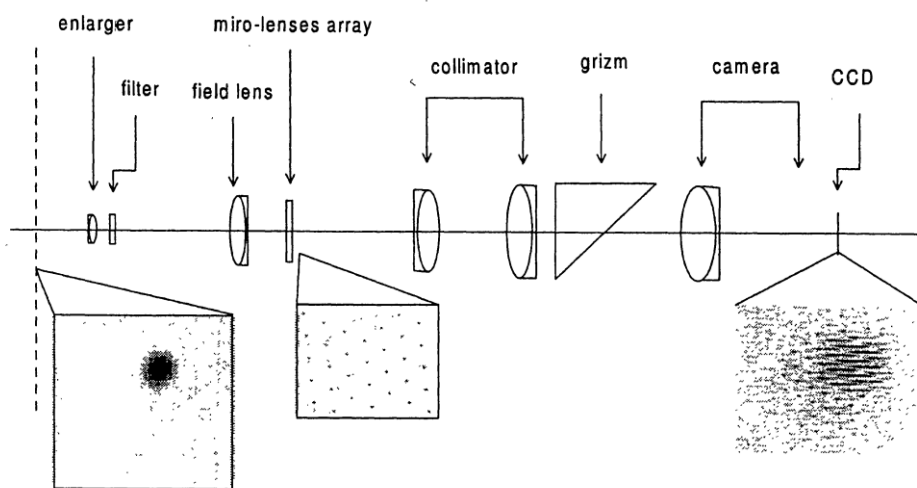

Fig. 3. Optical scheme of the VAGR spectrograph.

The schematic layout of the optical configuration is illustrated in the Fig.3. The field of view is enlarged and focused onto the micro-lenses array by an objective and field lens, which also makes telecentric beams on the micro-lenses array. The array performs the spatial sampling. Each micro-lens creates an image of an exit pupil, whose size is much smaller than the input lens diameter. The

remaining part is the classical wide field grism-based spectrograph. Each micro-pupil, dispersed by grism, gives a spectrum on the CCD. Slight rotation between the dispersion axis and the micro-lenses array, combined with wide-band interference filter, helps to avoid the overlap between spectra. Only the classical refractive optics is used in the spectrograph.

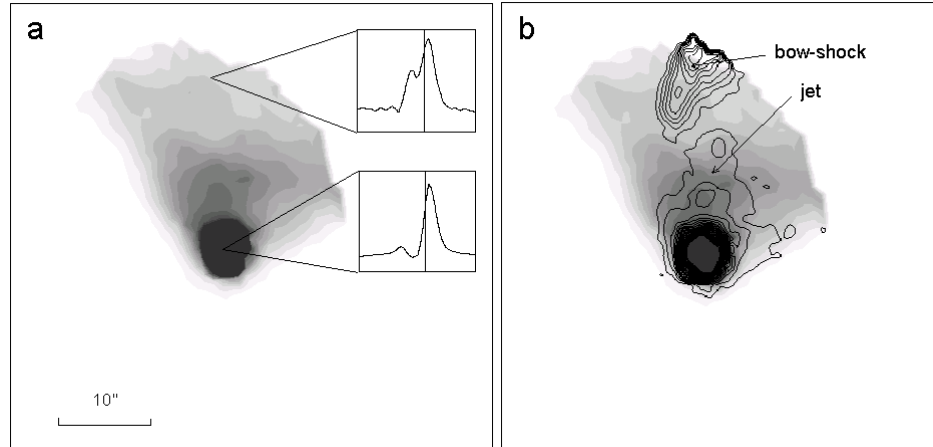

Fig. 4. Superposition of the restored image of PV Cep star associated with reflection nebula in H α emission (contours) and in continuum (gray scale) is shown on the right panel. On the left panel the profiles of H α emission in the position of the source and the bow-shock are presented.

1m Schmidt telescope

During 2015 the full modernization of 1m Schmidt telescope of Byurakan was nearly finished and only the auto-guiding system remains to be constructed. In the frame of modernization all analog devices were replaced by the digital ones, and new control system was developed. Besides, the dome control was automated as well. In the table the main parameters of the telescope are presented.

In the focal plane of the telescope 4k \times 4k Apogee CCD camera is mounted, providing one square degree field of view with 0.88 arcsec/pix resolution. Detector is equipped with the thermo-stabilized liquid-cooled Peltier system, providing about one degree temperature stabilization. Focusing tube is equipped with step motor and linear encoder, providing quick focusing during the observations. In front of the detector the five position filter wheel with 50 mm round filters is attached. The full filter set includes 21 medium-band filters, covering the full spectral range used to obtain SED's of astronomical objects. In addition five SDSS and three narrow-band filters, centered on the important emission lines, are available.

Table 2 gives the main characteristics of the telescope and its equipment.

On the Fig. 5 the “first light” image, obtained with Schmidt telescope after the modernization, is presented.

Table 2. Basic parameters of 1m Schmidt telescope and its equipment.

Telescope mirror:	
Diameter	1320 mm
Focal Length	2130 mm
Image Scale	96.7 "/mm
Field of View	~16 sq. deg.
Corrector Lens	1020 mm
Objective Prisms:	
Diameter	1000 mm
1.5 deg	1800 A/mm
3.0 deg	900 A/mm
4.0 deg	280 A/mm
Detector:	
Kodak KAF-16803	4k×4k
Pixel Size	9μm×9μm
Readout Noise	11 e
Dark Current	< 0.01 e/sec
Q.E.	60 % (5500 A) 35 % (3500 A) 18 % (9000 A)
Field of View	~ 1 sq. deg
Image Scale	0.88 arcsec/pix



Fig. 5. Direct image of the NGC 7331 obtained with 1m Schmidt camera after modernization (“first light”).

References

Afanasiev V.L. and Moiseev A.V., *Astronomy Letters*, 2005, 31, No.3, 193

Bessell, M.S., 1990, *PASP*, 102, 1181

Courtés, G., 1960, *Ann. d’Astrophysics*, 23, 115

Courtés, G., 1964, *AJ*, 69, 325

Courtés, G., 1982, *ASSL*, 92, 123

Movsessian T., Gach J.-L., Boulesteix J., Zhamkotsian F., *Baltic Astronomy*, 2000, 9, 518

Movsessian T., Boulesteix J., Gach J.-L., Zaratsian S., Balayan S., Zakarian M., *Baltic Astronomy*, 2000, 9, 652

*Dr. Tigran Movsessian,
BAO Deputy Director on Instrumentation*

Kazakhstan and Tajikistan Joined IAU South West Asian ROAD



In October 2015, IAU South West Asian Regional Office of Astronomy for Development (SWA ROAD) was officially opened in Byurakan Astrophysical Observatory (BAO) and Armenia became a regional astronomical centre. It is one of the 8 such centres established in frame of the IAU Strategic Plan and is going to coordinate the development of astronomy in our region. Beside Armenia, Georgia and Iran were joined this centre. The official webpage is at <http://iau-swa-road.aras.am/eng/index.php>.

Recently, during June 2016, **Kazakhstan** and **Tajikistan** with official letters also joined our ROAD. This significantly strengthens our centre and expands its sphere of activities to Central Asia.

In Kazakhstan, [Fesenkov Astrophysical Institute \(APhI\)](#), Almaty (founded in 1941) is the main astronomical centre. At present *Dr. Rashit Valiullin* is the Director. One of the outstanding scientists, Prof. Eduard Denissyuk, was one of the first astronomers to spectroscopically observe Markarian galaxies and has long-year collaboration with BAO astronomers. There are three attached observatories to APhI: Kamenskoe Plateau Observatory (altitude 1450m, AZT-8 70cm, Zeiss-600 60cm, Hertz telescope-reflector 50cm, Wide aperture Maksutov meniscus telescope 50cm), Tian-Shan Observatory (TShAO, altitude 2735m, two 1m telescopes) and Assy-Turgen Observatory (altitude 2750m, 1m telescope). The research subjects are: *physics of stars and nebulae; physics of the Moon and planets; cosmology, stellar dynamics & computational astrophysics; nuclear astrophysics; artificial Earth satellites; advanced astrophysical research.* [Kazakh National University \(KazNU\)](#) (with 16,000 students) is the main university preparing professional astronomers/astrophysicists.



Main building of Fesenkov Astrophysical Institute in Almaty, Kazakhstan

In Tajikistan, [Institute of Astrophysics](#) of Academy of Science of the Republic of Tajikistan, in Dushanbe (founded in 1932) is the main astronomical centre. At present *Dr. Gulchehra Kokhirova* is the Director. *Profs. Pulat Babadjanov* and *Khursand Ibadinov*, former directors and most eminent Tajik astronomers, are still active and strongly supported collaboration in frame of IAU ROAD as well. There are three attached observatories: Hissar Observatory (HisAO, altitude 730m, AZT-8, 40cm astrograph), the observatory “Sanglokh” (altitude 2300m) in Dangara area (1m telescope, 60cm Carl Zeiss) and its branch, the observatory “Pamir” (altitude 4350m) in Murghab district of Badakhshan (70cm telescope). Sanglokh observatory was recently re-operated and the President of Tajikistan was personally present. The research subjects are: *comets and asteroids, experimental astrophysics, meteor astronomy, ionospheric, astrometry, variable stars, structure and dynamics of stellar systems.*



1m telescope of Sanglokh Observatory.

Due to the involvement of Kazakhstan and Tajikistan, our regional centre was renamed to **IAU South West and Central Asian (SWCA) ROAD**. Corresponding changes and additions are done at our webpage.

The status of the regional astronomical centre supports the regional and international contacts and collaboration both for Armenia and the neighboring countries; this way Armenia, by holding such a centre, strongly contributes to collaborations at all levels: professional, educational and popular. Astronomy in fact plays an important political role in establishing and strengthening friendship and cooperation of the regional nations, which is especially important in our complicated area.

*Dr. Areg Mickaelian,
Director, IAU SWCA ROAD.*

ASTROBIOLOGY MATTERS IN ARMENIA

ArAS gives importance to the development of various fields of astronomy and astrophysics and related areas independent of their presence among BAO research subjects. Among these, we have already investigated enough **Astroinformatics**, as well as **Archaeoastronomy and Astronomy in Culture (AAC)**. Astroinformatics is directly related to Virtual Observatories, and Armenia is one of the countries holding such a national project, [Armenian Virtual Observatory \(ArVO\)](#). ArVO is an IVOA member and DFBS is a unique database providing low-dispersion spectroscopic data for nearly 20,000,000 objects. During the recent years, AAC is being intensely developed and promoted at various levels. We have organized several meetings, have written papers and coordinate this area in collaboration with the scientists from many other fields.

Astrobiology is one of the rapidly developing interdisciplinary fields in the world. It is a collaboration between astronomers and biologists. However, in Armenia, until now there is a very little progress in this area. ArAS has several times tried to introduce and develop Astrobiology in Armenia. The first attempt was in 2009, during the International Year of Astronomy (IYA-2009), when many such astronomy related interdisciplinary and multidisciplinary fields were involved being part of IAU Strategic Plan of Astronomy for Development. During the **ArAS VIII Annual Meeting** (06-08.07.2009), we organized a dedicated half-day Astrobiology session on July 7 with only 5 talks and a discussion. The next somewhat larger involvement was in 2014 during the meeting *“The Relation of Astronomy to other Sciences, Culture and Society” (RASCS)*, which was combined with **ArAS XIII Annual Meeting** (07-10.10.2014). We organized another half-day Astrobiology session on October 7 with more 5 talks. Anyway, our experience shows that there are no specialists in Armenia who could initiate Astrobiology projects and promote this field.



Recently, during the visit of ANSEF winners to BAO, where a number of actively working biologists were present from both Yerevan State University (YSU) and NAS RA Institute of Molecular Biology, there was a very short discussion on Astrobiology. The interest was so high that it was decided to have a dedicated meeting for further discussions. *Dr. Nelli Hovhannisyan*, Head of a Chair at YSU Department of Biology, invited *Dr. Areg Mickaelian* to deliver a **Department of Biology seminar** for YSU specialists and students. The seminar was held on June 3, 2016 and was entitled *“Astrobiology and Extrasolar Planets”*.

During the seminar, Astrobiology related taxonomy (Cosmic Biology, Astrobiology / Bioastronomy / Exobiology, Alternative Biology, Abiogenesis, Cosmic Panspermia, Extremophiles Studies, Extraterrestrial Intelligence, Paleovisitation, Astrochemistry, Molecular Astronomy, Astroecology,

Astrogeology, Astrology, etc.), the origin of the life on the Earth, signs of life on other planets and other celestial bodies, Extraterrestrial Intelligence (SETI/CETI), cosmic catastrophes, Exoplanets, habitable planets, and the rational part of Astrology were presented. There are a number of international organizations, institutes and councils related to Astrobiology, including the NASA Institute of Astrobiology. A number of international meetings are being organized every year and a number of international journals are being published, including *Astrobiology*, *International Journal of Astrobiology*, *International Journal of Infrared and Millimeter Waves*, *Advances in Astrobiology and Biogeophysics*, and *Astrobiology Magazine*. A special emphasis was made on the astronomical part of the problem, i.e. search and studies of Extrasolar Planets (Exoplanets). Methods of their discovery (radial velocities, astrometry, transit, imaging and many others), detection results and statistics, studies of various physical parameters of Exoplanets and their host stars, search for potentially habitable Exoplanets, and many other aspects were presented.

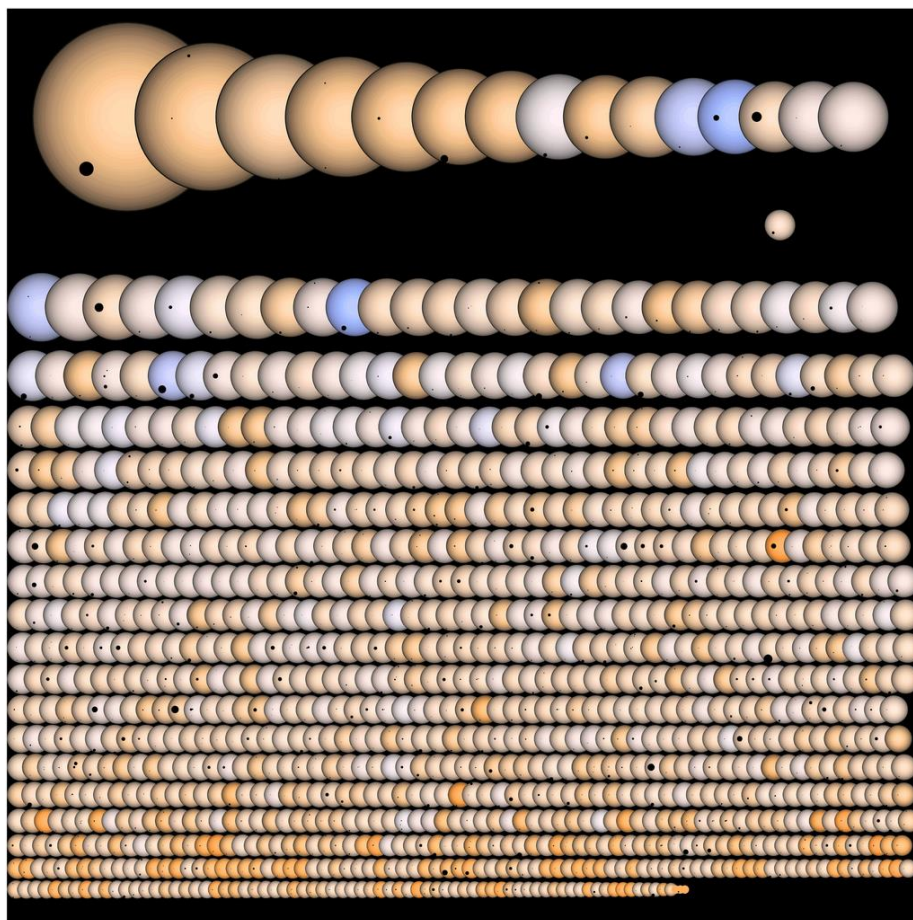

The seminar was followed by discussions on possible further collaboration and projects. Its forms may be rather different: joint supervision of B.Sc., M.Sc. and Ph.D. students, organizing joint seminars, workshops and conferences, creation of a joint laboratory, joint projects (including SCS Thematic, ANSEF, H2020 RISE encouraging interdisciplinary studies and many others), joint publications, participation in international meetings, etc. We will be happy if more specialists are involved and contribute to this area.

*Dr. Areg Mickaelian,
ArAS Acting President.*

“Cultural Astronomy in Armenian Highland” Young Scientists Conference



“Cultural Astronomy in Armenian Highland” Conference for Young Researchers devoted to the role of astronomy in culture and other fields of human activity was held on June 20-23, 2016 in Armenia.

The meeting contributed on: Astronomical heritage of Armenian, Ancient astronomy, Astronomy in the Middle Ages, Astronomy in ancient cultures, Ethnoastronomy, Astronomical bases of Philosophy, Religion and Astronomy, The problem of Extraterrestrial Intelligence, Astronomy and Astrology, Astronomy in Folklore and Poetry, Astronomy in Arts, Astronomy in Fashion, Astrolinguistics, Astroheraldry, Scientific Tourism, Scientific Journalism, Amateur Astronomy, Astronomical Education, Popular Astronomy Meetings and Schools.

In modern era, astronomy is probably the field of science, which plays a leading role in the formation and development of interdisciplinary sciences. For a long time the astrophysics has reached high level of development, recently new science disciplines have been created, such as astrochemistry, astrobiology, astroinformatics, astrolinguistics, archaeoastronomy plays important role in culture and in the heritage of nations, chronologies and calendars created on the basis of astronomical knowledge, etc. Cultural Astronomy also plays an important role in the development of scientific tourism and scientific journalism. The meeting is aimed at the development of problems of interdisciplinary sciences in Armenia and preparation of a basis for further possible collaborations by means of presentations of available modern knowledge in various areas of culture by experts from different professions and by joint discussions.



The Proceedings of the meeting will be published as an individual book by NAS RA Publishing House. The deadline for submission of papers is July 30, 2016. Number of allocated pages: Invited talks, 10 pages and Contributed talks, 6 pages.

The meeting was fulfilled with contribution of Swiss Cooperation South Caucasus and Support Program for Young Scientists.

*Sona Farmanyan,
Chair of LOC, AAC Young Scientists Conference*

ANSEF Grant Call



A.N.S.E.F.



The Armenian National Science & Education Fund

The Armenian National Science & Education Fund invites grant applications for the 2017 competition. Applicants are to submit their applications through the ANSEF website portal, accessed from the top bar of the ANSEF website (www.ansef.org) or directly through the link ansef.herokuapp.com. The deadline for submissions is August 31, 2016. Competition results will be announced early January 2017. For further questions, contact help@ansef.org.

For 2017, we have funds for a total of 30 grants. Five of these are provided through the support of the Young Scientists Support Program under the auspices of the RA President..



If you have applied for an ANSEF grant in the past through our portal, you may use your old account to submit new applications. If you have forgotten your password, the portal allows you to reset it and log in with a new password. This allows you to access all your past information in your new proposals. Watch the **video tutorials** on the portal's login page for more instructions.

If you are a **new applicant** who have not used the ANSEF portal before, you need to use the portal to first register. You will then receive an email to confirm your new account, and then proceed with logging in.

For any technical questions about the ANSEF portal, please contact website@ansef.org.

Past ANSEF grants on astronomical subjects

2016

Areg Mickaelian (BAO), Multiwavelength Studies of Blazar

Hayk Abrahamyan (BAO), Radio properties of active galaxies

Narek Sahakyan (NAS RA ICRA Net – Armenia Center), High energy gamma-rays from radio galaxies

Aram Saharian (Yerevan State University), Influence of topological defects on the electromagnetic vacuum fluctuations in de Sitter space-time

2015

Aramyan L. (BAO), The influence of various triggers of star formation on supernova rates

2014

Mickaelian A.M. (BAO), X-ray properties of active galaxies

Hakobyan A.A. (BAO), Study of Supernovae and their host galaxies in the far ($z \sim 0.3 - 0.6$) Universe

2013

Balayan S.K. (BAO), Software for control 1m telescope bao

Hakobyan A.A. (BAO), Supernovae distribution and host galaxy properties

Movsessian T.H. (BAO), Investigation of the internal structures in the jets from young stars

2012

Mickaelian A.M. (BAO), Study of Multiwavelength Properties of Markarian Galaxies using Virtual Observatory

Movsessian T.H. (BAO), Spectro-imagery of Herbig-Haro jets with scanning Fabry-Perot interferometry

Yeghikyan A. (BAO), Theoretical investigation of cosmic ray and ultraviolet radiation processing of astrobiologically relevant ices in interstellar molecular clouds

2011

Andreasyan R.R. (BAO), The differences in the morphology and physical properties in parent galaxies of nearby extragalactic radio sources and other elliptical galaxies of the same luminosities and red shifts from the field

Hakobyan A.A. (BAO), Study of the supernova progenitors via their host galaxies from the SDSS DR7

Magakian T.Yu. (BAO), Searches of young stellar objects by H-alpha and CaII emission

Sargsyan L.A. (BAO), Dust obscuration and velocity distribution in narrow line regions of AGN

2010

Hakobyan A.A. (BAO), Different Type of Supernovae, Stellar Population and Star Formation in Galaxies

Mahtesyan A.P. (BAO), Two-point correlation functions of groups and clusters of galaxies, radio galaxies and quasars

2009

Ohanian, G.A. (BAO), Integral Field Spectroscopy of Different Types Radio Galaxies with Various Linear Sizes

2008

Nikoghosyan, E.H. (BAO), The investigation of the very active star formation region in Cygnus OB7 complex

Sadoyan, A.A. (YSU), Investigation of Gravitational Wave Sources in Medium Frequency Band

2007

Balayan S.K. (BAO), Reconstruction of the BAO 1m Schmidt Type Telescope

Mickaelian A.M. (BAO), Science with the Armenian Virtual Observatory

2006

Mahtesyan A.P. (BAO), The Influence of the Surroundings on the Physical Characteristics of Galaxies in Groups

Nikoghosyan, E.H. (BAO), Search and the Proper Motions of Herbig-Haro Objects in the Star Forming Regions

Ter-Kazarian G.T. (BAO), Multi-Nuclei Features of Markarian Galaxies and Physical Mechanism Beyond

2005

Andreasyan R.R. (BAO), The 3-D structure of the magnetic field of the Galaxy

Saharian A.A. (YSU), Casimir Densities and Induced Cosmological Constant in Higher-Loop String Cosmology

Sedrakyan D.M. (YSU), Gravitational Waves from Relativistic Superdense Stellar Objects

2004

Andreasyan R.R. (BAO), The Distribution of Free Electrons in the Galaxy

Hakopian S.A. (BAO), 3D-study of SBS galaxies

Ter-Kazarian G.T. (BAO), An Activity of Galactic Nuclei and Superdense "Protomatter" Sources in the Universe

2003

Movsessian T.H. (BAO), Multi-Component Investigation of Extragalactic Radio Sources

Vardanyan Yu.L. (YSU), Quark Matter in Superdense Stellar Objects

Zalinian V.P. (BAO), Updating the Control of the Telescope ZTA-2.6

2002

Hovhannisyan M.A. (BAO), The Investigation of the Extended Radio Galaxies

Magakian T.Yu. (BAO), Searches and Detailed Studies of Outflows from PMS Stars

Mickaelian A.M. (BAO), Digitization of the First Byurakan Survey (FBS)

Shahabasyan K.M. (YSU), Problems of Magnetic Field Behavior and Rotational Dynamics of Pulsars

2001

Khachikian E.Ye. (BAO), Radio and Optical Investigations of Extragalactic Objects

Mickaelian A.M. (BAO), Study of Starburst/AGN/Interaction Phenomena in IRAS Galaxies

Saharian A.A. (YSU), Dynamics of Higher-Loop String Cosmology and Dilation Stabilization

ArAS Prize 2016 Call

ArAS is pleased to announce the **ArAS Annual Prize for Young Astronomers (Yervant Terzian Prize) 2016**. The prize will be awarded to a young scientist under 35 working in astronomy or related field and showing significant results in research and/or other scientific activities connected anyhow with the Armenian astronomy. **Nominations** may be made by ArAS members or any research organization from Armenia or elsewhere and should be sent to one of the ArAS Co-Presidents (Haik Harutyunian, Areg Mickaelian or Yervant Terzian).



Nominations should include personal data of the nominee (first name, surname, affiliation, position, education, degree, birthdate, e-mail address, personal homepage if available) and a brief description of his/her achievements during the year (2016) including:

1. Scientific results (up to 1 page)
2. Letter from the supervisor describing the personal contribution of the nominee
3. Published, accepted and submitted papers (in refereed journals, in proceedings of meetings, and other)
4. Participation in meetings and schools
5. Given talks, seminars, and presented posters
6. Scientific mission
7. Honours, awards and research grants
8. Membership
9. Teaching activity
10. Organizational activity
11. Other activities, whatever is considered to be important

At least one refereed publication is required to qualify for the Prize. Preference will be given to nominees having publications in journals with higher impact factors (IF), with less co-authors and papers with the nominee as the first co-author, as well as the own contribution stated by the supervisor will be rather important. Nominations will be discussed and the winner(s) will be named by the ArAS Council (Haik Harutyunian, Tigran Magakian, Areg Mickaelian, Elena Nikoghosyan and Yervant Terzian).

The **deadline** for applications is **December 1**. The winner will be announced in the last issue of ArAS Newsletter (#100) at the end of the year. A **diploma** and sum of **\$500** will be awarded to the winner. The Prize was established in 2004 and is being sponsored by ArAS Co-President **Prof. Yervant Terzian** (Cornell University, USA). Since 2009 the Prize is named after Yervant Terzian.

Previous ArAS Annual Prize (Yervant Terzian Prize) Winners

2015 Artur HAKOBYAN (BAO)

2014 Gurgen PARONYAN (BAO)

2013 Hayk ABRAHAMYAN (BAO) and Avet HARUTYUNYAN (IAC, Spain)

2012 Vardan ADIBEKYAN (CAUP, Portugal)

2011 Marine AVTANDILYAN (ASPU)

2010 Parandzem SINAMYAN (BAO)

2009 Lusine SARGSYAN (BAO)

2008 Vardan ADIBEKYAN (YSU) and Artur HAKOBYAN (BAO)

2007 Igor CHILINGARIAN (OBSPM, France)

2006 Lilit HOVHANNISYAN (BAO) and Parandzem SINAMYAN (BAO)

2005 Artak HARUTYUNYAN (BAO) and Elena HOVHANNESIAN (BAO)

2004 Lusine SARGSYAN (BAO)

RELEASE OF ASTROPHYSICS JUNE ISSUE



To the Memory of A. T. Kalloghlian

Periodic Brightness Modulation of the T Tauri Star V716 Per Based on Optical and Infrared Photometry

O. Yu. Barsunova, V. P. Grinin, A. A. Arharov, A. O. Semenov, S. G. Sergeev...

Magnetic Stars After the Hayashi Phase. I

Yu. V. Glagolevskij Pages 164-182

IV-Th Great Visual Light Minimum of R CrB. I. UBVRIC Photometry

A. E. Rosenbush

Singular-Spectrum Analysis and Wavelet Analysis of the Variability of the Extragalactic Radio Sources 3C 120 and CTA 102

G. I. Donskikh, M. I. Ryabov, A. L. Sukharev, M. Aller

Predicting Changes in the Radio Emission Fluxes of Extragalactic Sources

A. L. Sukharev, M. I. Ryabov, G. I. Donskikh

Polarization of Resonance Lines in the Case of Partially Polarized Primary Radiation Sources

A. V. Demytyev

Kinematics and Velocity Ellipsoid Parameters of Stellar Groups and Open Star Clusters: II Cool Stars

W. H. Elsanhoury

Two Interesting Southern Objects

A. L. Gyulbudaghian

Anticyclonic Vortex in a Protoplanetary Disk

M. G. Abrahamyan

Internal Radiation Field in the Nonlinear Transfer Problem for a One-Dimensional Anisotropic Medium. II

H. V. Pikichyan

A Stringent Limit on Variation of the Fine-Structure Constant Using Absorption Line Multiplets in the Early Universe

T. D. Le

Erratum to: Distribution of Pulsars in the Galaxy

H. R. Andriasyan, R. R. Andriasyan, G. M. Paronyan

RELEASE OF ASTROCOURIER JUNE ISSUE

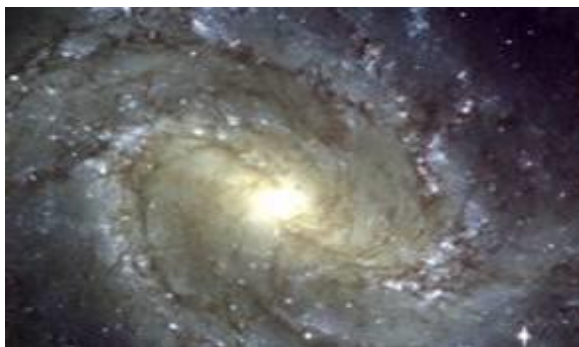

CONTENTS

PREFACE

Board of the International Public Organization "Astronomical Society" is in Belgrade

ANNIVERSARIES:

Shklovsky's 100th Anniversary

Phenomenon of Shklovsky

The album of Shklovsky

The Beginning of Gravitational Astronomy

ANNOUNCEMENTS:

The News of International Astronomical Union

CHRONICLE OF EVENTS

50th Anniversary of SAO

145th Anniversary of Odessa Astronomical Observatory

Brian May announced Asteroid Day

Asteroid Day in Moscow Planetarium

To the Memory of E. Yanovitsky

Astrocourier Newsletter is available in the following link:

<http://www.sai.msu.ru/EAAS/rus/astrocourier/300616.htm>

RELEASE OF IAU ASTRONOMY OUTREACH NEWSLETTER 2016 #12, June #3

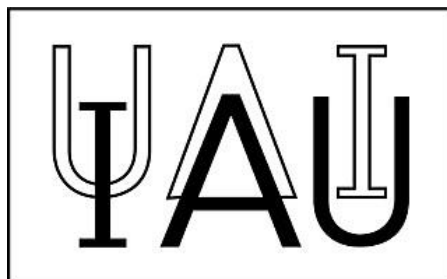

In this newsletter:

From the Editors

IAU Office of Astronomy for Development Newsletter #12

CAP2016 Conference - Presentations now online

Beyond Cosmic Light: Quality Lighting Teaching Kit

National Outreach Contact (NOC) Corner: News from the USA

Celebrate the 4th of July with Juno!

The Arab Conference of Astronomy and Geophysics

Astronomy PH

7th International Earth and Sky Photo Contest

Meetings & global events for 2016

a. Recently added

b. Important deadlines

c. Upcoming

IAU Astronomy Outreach Newsletter in other languages

Contributions to IAU Outreach Newsletter for 2016



LUNAR PHASES OF JULY

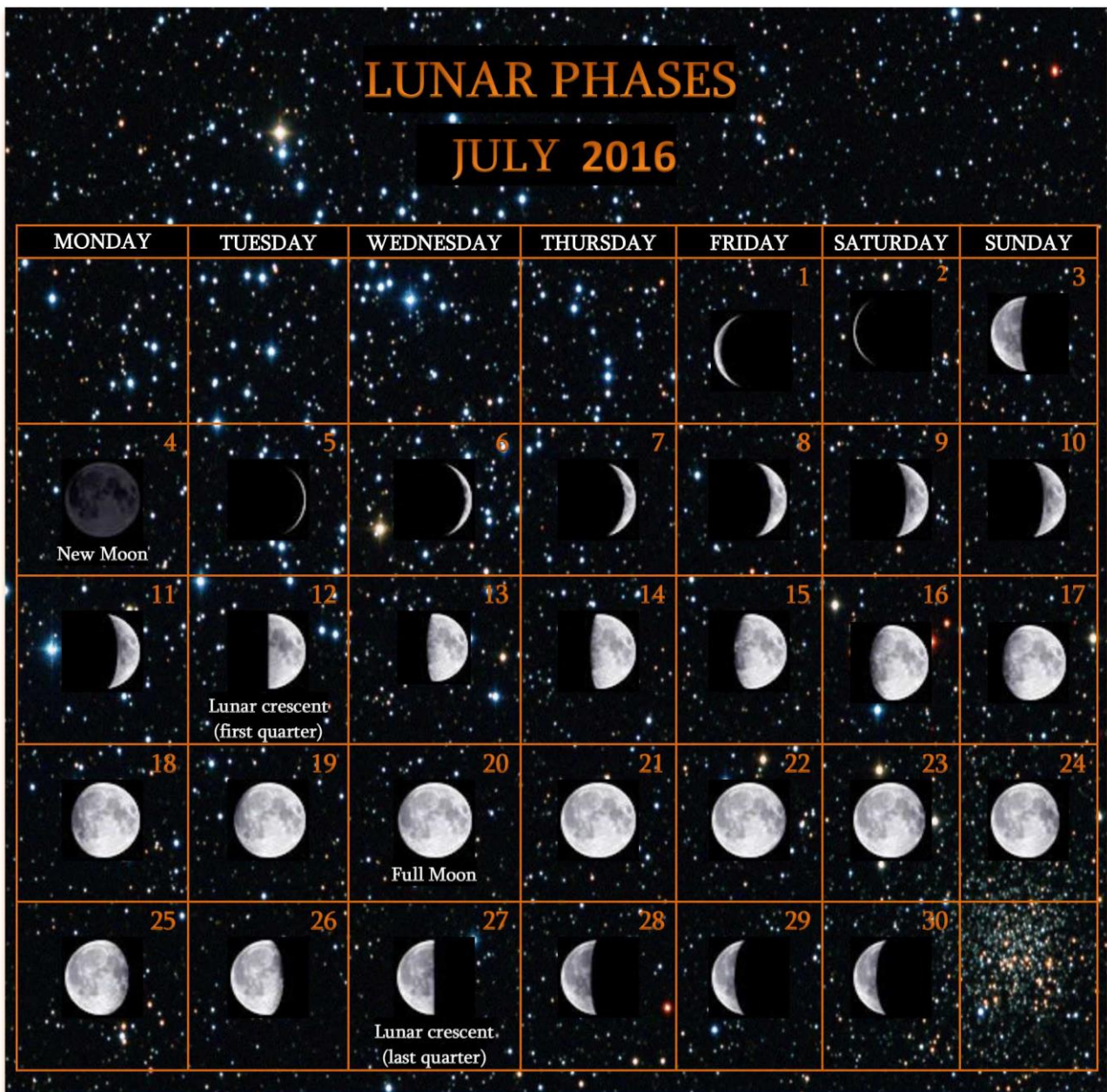

JULY CALENDAR OF ASTRONOMICAL EVENTS

Monthly Calendar of Astronomical Events
JULY 2016

Monday	Tuesday	Wednesday	Thursday	Friday	Saturday	Sunday
				1	2	3
4 European Week of Astronomy and Space Sciences: EWASS-2016	5	6	7	8	9 Lunar occultation of Jupiter	10
11	12 Lunar crescent (first quarter)	13	14	15	16 Conjunction of Mercury vs. Venus	17 Cassiopeids meteor shower's peak
18 Southern and Northern Delta Aquarids meteor shower's peak	19	20 Full Moon	21	22 IAU Symposium #322: The Multi-Messenger Astrophysics of Galactic Centre (18-22)	23 Lunar occultation of Neptune Perseids meteor shower's peak	24
25	26	27 Lunar crescent (last quarter)	28	29	30 ArAS Newsletter #95 Release	31